

EE 70 Midterm #2
Closed Book, Calculators Allowed
One Page of Notes Allowed (8.5" x 11", both sides ok)

Wednesday, May 14th (2 pm – 3:10 pm)
15 problems, 30 total points

Please do all of your work on a separate sheet of paper
Final answers should be circled next to your work
To receive full (or partial) credit, you must show your work
Unless otherwise specified, each question is worth two points

For problems 1–5, consider the following circuit:

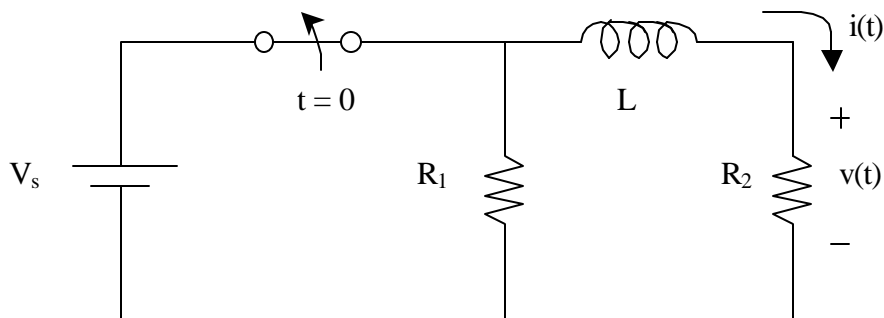

Use $V_s = 5$ v, $R_1 = 5$ Ω , $R_2 = 10$ Ω , and $L = 1$ H. After a long time has elapsed, the switch is opened at $t = 0$. We want to find the voltage $v(t)$, and current $i(t)$, across R_2 as a function of time.

- 1a. Redraw the circuit, showing how the circuit looks just before the switch is opened.
- 1b. Using this result, find $v(0^-)$.
- 2a. What is the continuity/boundary condition for this circuit at $t = 0$?
- 2b. Find the numerical value of the boundary condition.
3. Write a KVL equation for the circuit after the switch as been opened at $t = 0$. (note: do *not* use the circuit you drew in #1a). Convert the voltages into currents.
4. Solve the differential equation generated in #3 for $i(t)$. Clearly show how you obtained all of the numerical values in $i(t)$.
5. Sketch curves of $i(t)$ and $v(t)$ as a function of time ($-\infty < t < \infty$). Indicate all critical and asymptotic values.

For problems 6–10, consider the following second-order circuit:

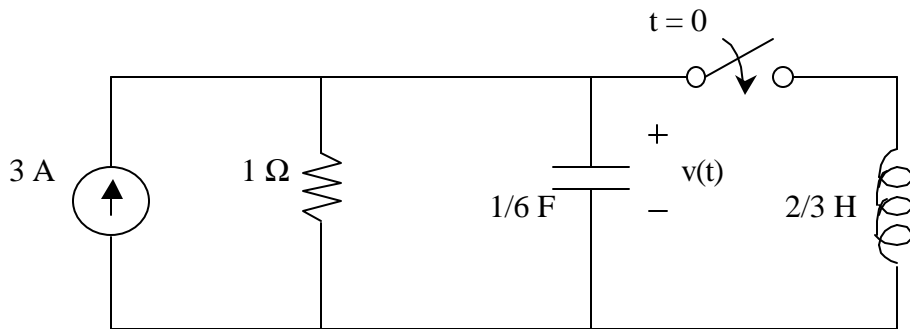

The switch is closed at $t = 0$. The goal is to find the voltage across the capacitor, $v(t)$.

- 6a. Assume that the switch has remained open for a long period of time. Find $v(0^-)$.
- 6b. What should $v(0^+)$ be? Explain.
- 7a. Before the switch is closed, what is the current through the inductor? Explain.
- 7b. Using the results from #7a, #6, and continuity requirements, find the current through the capacitor at $t = 0^+$.
8. Derive the second-order differential equation for this circuit. Start by writing a KCL equation. Then convert the currents in each passive element into voltages.
- 9a. What form should be chosen for the homogeneous solution?
- 9b. Substitute your choice of the homogeneous solution into the differential equation. Solve the corresponding characteristic equation.
10. Finish determining $v(t)$ by using the results in 6b and 7b to find any constants you have defined in your solution for $v(t)$. (Hint: if you know the voltage across the capacitor, you can find the current across the capacitor)

For extra credit:

In this particular problem, no particular solution was necessary because the second-order differential equation derived in #8 has no forcing function. Does this make sense when looking at the circuit? Explain. (Hint: think about what the particular solution represents and analyze the circuit at steady state)

For problems 11–15, consider the following op-amp circuit:

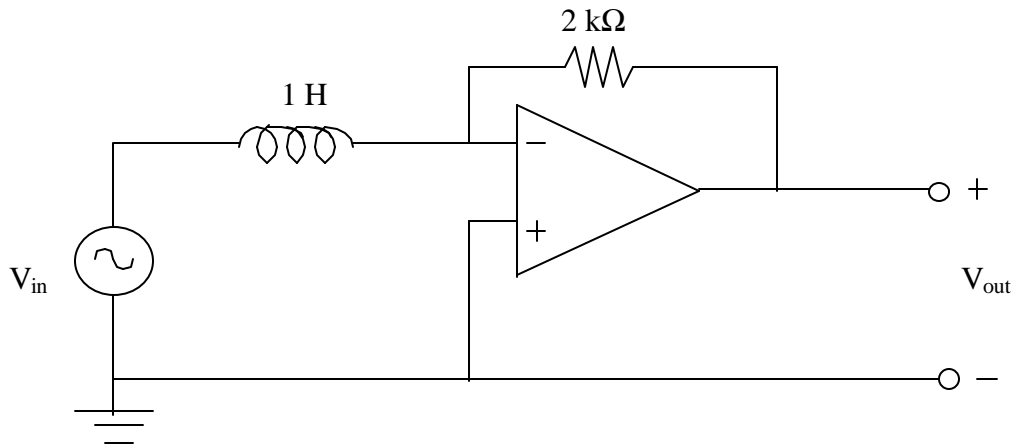

Assume ideal op-amp conditions (i.e. summing-point constraint applies)

11. Use KCL to find an equation for V_{out} in terms of V_{in} (in the time domain).
12. If the input source is $V_{in} = 2 \sin(4t + 30^\circ)$, what is V_{out} ?
13. Check your results to #12 by doing an analysis in the frequency domain. First, using KCL and complex impedances, write an equation for V_{out} versus V_{in} . (phasor relationship)
14. Convert the input signal into a phasor. Calculate the output signal (in phasor form). Convert your answer back into the time domain, and compare with #12.
15. Draw a phasor diagram for the input and output voltages. Also include the current through the inductor and the current through the resistor.