

University of California, Santa Cruz
Electrical Engineering Department, Analog Electronics Laboratory

Based on the notes by Stephen Petersen

EXPERIMENT 2: DIODE CHARACTERISTICS I.

DESCRIPTION AND OBJECTIVE

This laboratory experimentally determines two essential parameters found within the basic exponential diode equation: ideality factor n , and saturation or scale current I_S . We will use the basic non-linear transfer characteristics of a silicon junction diode to determine I_S and plot the measured I_D vs. V_D to show graphically the diode's inherent non-linear transfer characteristic. Ideality factor n will be found by application of the small-signal model where small-signal dynamic resistance r_d will also be observed experimentally. After completing this work, you should have a thorough understanding of the non-linear volt-ampere relationship in the diode's forward-bias region, as well as how to operate the diode so a linear input-output relationship holds for small-signal applications.

II. GENERAL CIRCUIT DISCUSSION

Consider the following two well-known equations:

$$[1] \quad I_D = I_S \left(e^{\frac{V_D}{nV_T}} - 1 \right)$$

where the thermal voltage $V_T = \frac{kT}{q} = 25mV$ at room temperature.

$$[2] \quad r_d = \frac{nV_T}{I_D}$$

The first equation describes the classic exponential relationship between the current through a junction diode as a function of the voltage drop across it, while eqn. [2] is the small-signal dynamic (or AC) resistance the diode exhibits when biased at a quiescent DC current I_D .

Remember this equation is an approximation holding only for small time-varying AC, or small-signal, inputs limited to about 10 mV in amplitude. The diode's current then varies nearly linearly with the small voltage changing across it, so we can treat the behavior of the diode as a linear resistor having r_d Ohms of resistance.

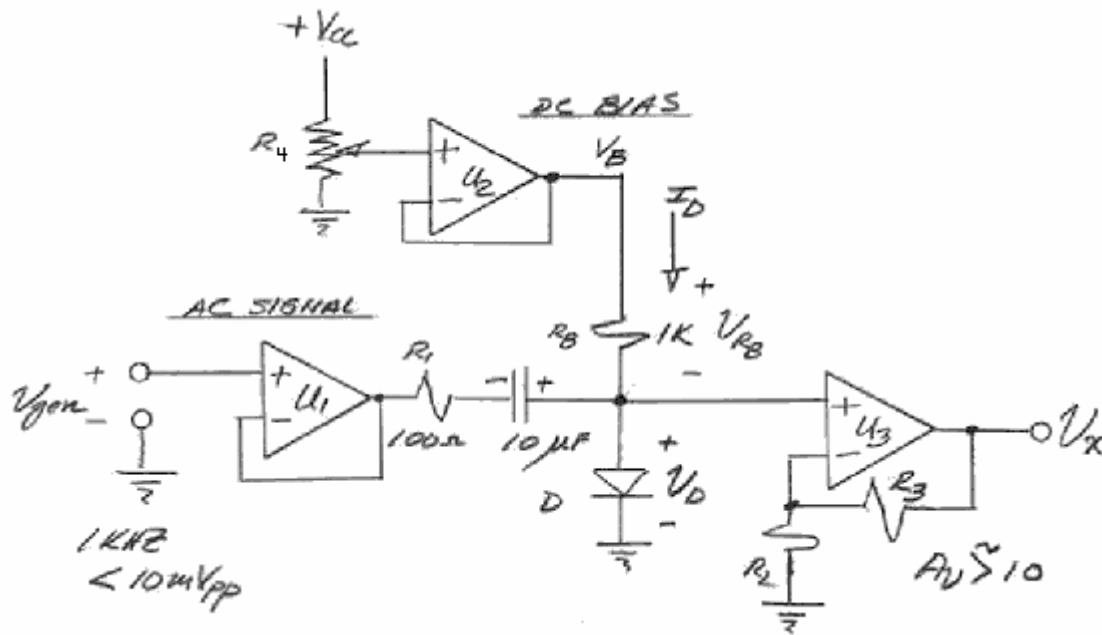

Figure 1. Practical circuit implementation.

Note: Re-draw this schematic in your engineering notes and make any experimental scribbles or annotations there.

Figure 2 shows the theoretical circuit we want to implement. Our work will be based on a practical implementation of this, shown in Figure 1. The Op-amps have been added to help maintain an approximately ideal testing environment.

Op-amp U_1 functions as a unity-gain buffer to isolate the unwanted effects of the signal generator's output impedance (which is typically 50 Ohms or greater). It provides the input signal for the main circuit at its output node.

Op-amp U_2 is used in a similar manner: diode current I_D will be found by calculation from the measured resistance of R_B and the measured voltage drop across it for various settings of R_4 . Without U_2 , the effective resistance seen looking back into this branch would change whenever resistance R_4 was changed. Op-amp U_2 provides the biasing DC current through the resistor at its output node.

V_{CC} and V_{EE} should be somewhere between 10 and 15 Volts. Keep track of their actual values and make sure they remain stable as you go through the experiment. Once set, try not to keep turning them on and off; rather, remove the interconnections when you want to de-energize things to make changes. You may also want to de-couple the power supply rails to avoid small-signal feedback paths through the power supply leads. Place $100\ \mu\text{F}$ (or larger) capacitors from V_{CC} and V_{EE} to ground where appropriate. You should have at least one to decouple V_{CC} and one for V_{EE} .

Op-amp U_3 is configured as a non-inverting amplifier with a voltage gain of about 11 [V/V]. It provides amplification of the small signal diode voltage v_D so that the oscilloscope can read it.

Take measurements to determine n from a spread of different dynamic resistances r_d . Summarize your data and these results (each one and the final average). Do these values closely agree? If not, why not?

Produce an accurate plot of I_D vs. V_D and indicate where your small-signal DC points are located. Draw a tangent line for the smallest and largest r_d found with a slope determined from actual values for a particular r_d . Do these lines actually appear to be tangent to their respective Q-points? Explain. Suppose your small-signal sinusoid were too large or overdriven, well over 10 mV_{pp} . What effect would this have on the determination of n by the method used here?

Summarize your data and results in tabular form for each point used to determine the scale current I_S .

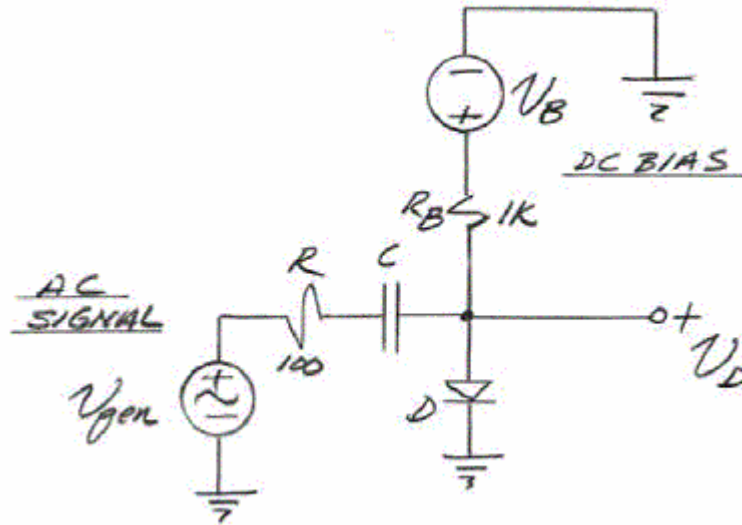

Figure 2. Theoretical diode circuit.

Note: **Re-draw this schematic in your engineering notes and make any experimental scribbles or annotations there.**

Recommended Procedure:

(Hint) Build and test each amplifier separately before assembling the full circuit

This is a complicated circuit, so assemble each of the three op-amp circuits before doing anything else. Test each one separately before connecting them together. This will help identify problems in parts of the circuit when it is simple enough to identify the source of the problem.

1. Determine ideality factor n from at least five different bias points using the small-signal equation [2].

A substitution procedure works best to accurately determine the dynamic resistance r_d . First, measure R_I (nominal 100 Ohms), R_B (nominal 1k) and one of the several resistances R_D (between 10 and 1000 Ohms) that will be used to calibrate r_d . Substitute R_D in place of the diode and adjust the signal generator for a small-signal sinusoidal output less than 10 mV_{pp} at 1 kHz (5 to 8 mV works well). The signal generators in the lab produce a minimum output voltage of 50 mV_{pp} so you must design yourself a voltage divider to reduce the output voltage into the desired range. Be sure to calibrate your voltage divider (used here as an attenuator) and check the voltage that you are actually applying using the scope.

First, put a resistor R_D in place of the diode with resistance between 10-1000 Ohms (again measure its actual resistance as the resistor values are different from resistor to resistor). Measure V_X , the output voltage of Op-amp U3. Now replace the resistor R_D with the diode and adjust the current through the diode until you get the same V_X as you measured with the resistor in place. The small signal resistance of the diode will now be equal to the value of R_D that you chose. You now know that r_d of the diode is equal to R_D and you can measure the current through it, I_D . You now know all the components of r_d given in equation 2 except for n , which you can now calculate. The ideality (or emission factor) n that you calculate should be somewhere between 1 and 3. Repeat this procedure for 5 different R_D calibration resistor values. Are the values that you calculate for n all the same? Why might they be different? Assuming that the n of the diode really is a constant, what is your best estimate of its value and how accurately do you think that you know it?

Investigate the effect of overdriving the diode, that is use a signal voltage of more than 10 mV_{pp} , try it and see what happens. It might provide insight into what is going on. This is much easier done in the lab by measurement or on a simulator than by hand calculation!

2. Determine the I vs V characteristic for the diode in the forward-bias region and use it to construct an accurate graph, and determine the scale current, also known as the reverse saturation current, I_S .

Simply vary V_B from about 5 mV to about 10.0 Volts and record V_B (the output of Op-amp U2), V_{RB} (the voltage across R_B) and V_D (the voltage drop across the diode). I_D can

then be found from the drop across R_B , and I_S from eqn.[1] using the value of n found earlier in part 1. You should also take enough points to construct an accurate graph of i_D vs. V_D . Inspect the results for I_S and determine the best estimate accordingly. Can you measure I_S directly? If not why not?

3. Determine the bandwidth of your attenuator.

How low can you turn the frequency generator frequency and still have this attenuator work with roughly constant attenuation? How high can you turn the frequency?

Determine the frequencies at which the output is attenuated from its peak by 3 dB. What is the bandwidth? Do these high and low frequency limits depend on the diode current I_D ? If so why? What components set the high and low frequency limits?

4. Spice Simulation

Problem 3.92 in the textbook.