

UNIVERSITY OF CALIFORNIA, SANTA CRUZ  
BOARD OF STUDIES IN COMPUTER ENGINEERING



CMPE 240: INTRODUCTION TO LINEAR DYNAMICAL SYSTEMS

PROBLEM SET 8

1. Two separate experiments are performed for  $t \geq 0$  on the single-input single-output (SISO) linear system

$$\dot{x} = Ax + Bu, \quad y = Cx + Du, \quad x(0) = [1 \ 2 \ -1]^T$$

(the initial condition is the same in each experiment). In the first experiment,  $u(t) = e^{-t}$  and the resulting output is  $y(t) = e^{-3t} + e^{-2t}$ . In the second,  $u(t) = e^{-3t}$  and the resulting output is  $y(t) = 3e^{-3t} - e^{-2t}$ .

- (a) Can you determine the transfer function  $C(sI - A)^{-1}B + D$  from this information? If it is possible, do so. If not, find two linear systems consistent with all the data given which have different transfer functions.
- (b) Can you determine  $A$ ,  $B$ ,  $C$ , or  $D$ ?
2. *A method for rapidly driving the state to zero.* We consider the discrete-time linear dynamical system

$$x(t+1) = Ax(t) + Bu(t),$$

where  $A \in \mathbf{R}^{n \times n}$  and  $B \in \mathbf{R}^{n \times k}$ ,  $k < n$ , is full rank.

The goal is to choose an input  $u$  that causes  $x(t)$  to converge to zero as  $t \rightarrow \infty$ . An engineer proposes the following simple method: at time  $t$ , choose  $u(t)$  that minimizes  $\|x(t+1)\|$ . The engineer argues that this scheme will work well, since the norm of the state is made as small as possible at every step. In this problem you will analyze this scheme.

- (a) Find an explicit expression for the proposed input  $u(t)$  in terms of  $x(t)$ ,  $A$ , and  $B$ .
- (b) Now consider the linear dynamical system  $x(t+1) = Ax(t) + Bu(t)$  with  $u(t)$  given by the proposed scheme (*i.e.*, as found in (2a)). Show that  $x$  satisfies an autonomous linear dynamical system equation  $x(t+1) = Fx(t)$ . Express the matrix  $F$  explicitly in terms of  $A$  and  $B$ .

(c) Now consider a specific case:

$$A = \begin{bmatrix} 0 & 3 \\ 0 & 0 \end{bmatrix}, \quad B = \begin{bmatrix} 1 \\ 1 \end{bmatrix}.$$

Compare the behavior of  $x(t+1) = Ax(t)$  (*i.e.*, the original system with  $u(t) = 0$ ) and  $x(t+1) = Fx(t)$  (*i.e.*, the original system with  $u(t)$  chosen by the scheme described above) for a few initial conditions. Determine whether each of these systems is stable.

3. *Analysis of cross-coupling in interconnect wiring.* In integrated circuits, wires which connect the output of one gate to the inputs of one (or more) other gates are called *nets*. As feature sizes shrink to well below a micron (*i.e.*, ‘deep submicron’) the capacitance of a wire to the substrate (which in a simple analysis can be approximated as ground), as well as to neighboring wires, must be taken into account.

A simple lumped model of three nets is shown below. The inputs are the voltage sources  $u_1, u_2, u_3$ , and the outputs are the three voltages labeled  $y_1, y_2, y_3$ . The resistances  $R_1, \dots, R_6$  represent the resistance of the wire segments. The capacitances  $C_1, \dots, C_6$  are capacitances from the interconnect wires to the substrate; the capacitances  $C_7$  and  $C_8$  are capacitances between wires 1 and 2, and wires 2 and 3, respectively. (The different locations of these cross-coupling capacitances models the wire 1 crossing over wire 2 near the driving gate, and wire 2 crossing over wire 3 near the end of the wire, but you don’t need to know this to do the problem ...) In static conditions, the circuit reduces to three wires (with resistance  $R_1 + R_2, R_3 + R_4$ , and  $R_5 + R_6$ , respectively) connecting the inputs to the outputs.

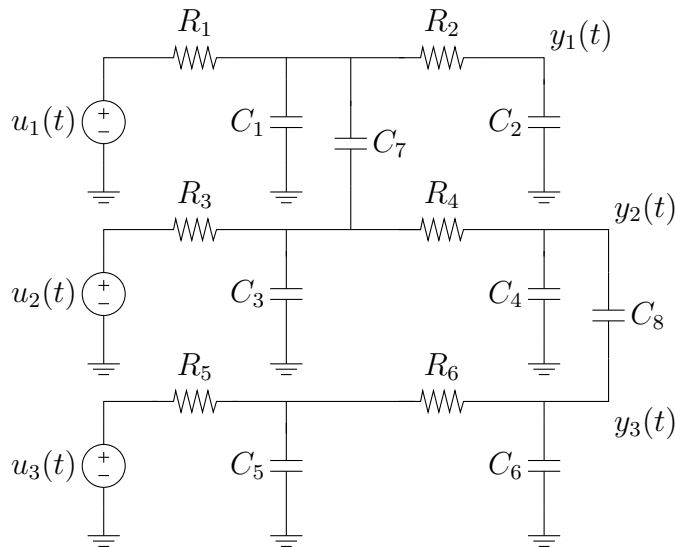

To simplify the problem we’ll assume that all resistors have value 1 and all capacitors have value 1.

We recognize that some of you don’t know how to write the equations that govern this circuit, so we’ve done it for you. (If you’re an EE student in this category, then shame on you.)

The equations are

$$C\dot{v} + Gv = Fu, \quad y = Kv,$$

where

$$C = \begin{bmatrix} 2 & 0 & -1 & 0 & 0 & 0 \\ 0 & 1 & 0 & 0 & 0 & 0 \\ -1 & 0 & 2 & 0 & 0 & 0 \\ 0 & 0 & 0 & 2 & 0 & -1 \\ 0 & 0 & 0 & 0 & 1 & 0 \\ 0 & 0 & 0 & -1 & 0 & 2 \end{bmatrix}, \quad G = \begin{bmatrix} 2 & -1 & 0 & 0 & 0 & 0 \\ -1 & 1 & 0 & 0 & 0 & 0 \\ 0 & 0 & 2 & -1 & 0 & 0 \\ 0 & 0 & -1 & 1 & 0 & 0 \\ 0 & 0 & 0 & 0 & 2 & -1 \\ 0 & 0 & 0 & 0 & -1 & 1 \end{bmatrix},$$

$$F = \begin{bmatrix} 1 & 0 & 0 \\ 0 & 0 & 0 \\ 0 & 1 & 0 \\ 0 & 0 & 0 \\ 0 & 0 & 1 \\ 0 & 0 & 0 \end{bmatrix}, \quad K = \begin{bmatrix} 0 & 1 & 0 & 0 & 0 & 0 \\ 0 & 0 & 0 & 1 & 0 & 0 \\ 0 & 0 & 0 & 0 & 0 & 1 \end{bmatrix}$$

and  $v \in \mathbf{R}^6$  is the vector of voltages at capacitors  $C_1, \dots, C_6$ , respectively. To save you the trouble of typing these in, we've put an mfile `interconn.m` on the course web page, which defines these matrices.

The inputs (which represent the gates that drive the three nets) are Boolean valued, *i.e.*,  $u_i(t) \in \{0, 1\}$  for all  $t$ . In this problem we will only consider inputs that switch (change value from 0 to 1 or 1 to 0) at most once.

- (a) *50%-threshold delay.* For  $t < 0$ , the system is in static condition, and the inputs have values  $u(t) = f$  for  $t < 0$ , where  $f_i \in \{0, 1\}$ . At  $t = 0$ , the input switches to the Boolean vector  $g$ , *i.e.*, for  $t \geq 0$ ,  $u(t) = g$ , where  $g_i \in \{0, 1\}$ . Since the DC gain matrix of this system is  $I$ , and the system is stable, the output converges to the input value:  $y(t) \rightarrow g$  as  $t \rightarrow \infty$ .

We define the 50%-threshold delay of the transition as smallest  $T$  such that  $|y_i(t) - g_i| \leq 0.5$  for  $t \geq T$ , and for  $i = 1, 2, 3$ . (If the following gate thresholds were set at 0.5, then this would be first time after which the outputs would be guaranteed correct.)

Among the 64 possible transitions, find the largest (*i.e.*, worst) 50%-threshold delay. Give the largest delay, and also describe which transition gives the largest delay (*e.g.*, the transition with  $f = (0, 0, 1)$  to  $g = (1, 0, 0)$ ).

- (b) *Maximum bounce due to cross-coupling.* Now suppose that input 2 remains zero, but inputs 1 and 3 undergo transitions at times  $t = T_1$  and  $t = T_3$ , respectively. (In part 1, in contrast, all transitions occurred at  $t = 0$ .) To be more precise (and also so nobody can say we weren't clear),

$$u_1(t) = \begin{cases} f_1 & \text{for } t < T_1 \\ g_1 & \text{for } t \geq T_1 \end{cases}, \quad u_3(t) = \begin{cases} f_3 & \text{for } t < T_3 \\ g_3 & \text{for } t \geq T_3 \end{cases}, \quad u_2(t) = 0 \text{ for all } t,$$

where  $f_1, f_3, g_1, g_3 \in \{0, 1\}$ .

The transitions in inputs 1 and 3 induce a nonzero response in output 2. (But  $y_2$  does converge back to zero, since  $u_2 = 0$ .) This phenomenon of  $y_2$  deviating from zero (which is what it would be if there were no cross-coupling capacitance) is called *bounce* (induced by the cross-coupling between the nets). If for any  $t$ ,  $y_2(t)$  is large enough to trigger the following gate, things can get very, very ugly. What is the maximum possible bounce? In other words, what is the maximum possible value of  $y_2(t)$ , over all possible  $t$ ,  $T_1$ ,  $T_3$ ,  $f_1$ ,  $f_3$ ,  $g_1$ ,  $g_3$ ? Be sure to give not only the maximum value, but also the times  $t$ ,  $T_1$ , and  $T_3$ , and the transitions  $f_1$ ,  $f_3$ ,  $g_1$ ,  $g_3$ , which maximize  $y(t)$ .

*Note:* in this problem we don't consider multiple transitions, but it's not hard to do so.

4. *Norm expressions for quadratic forms.* Let  $f(x) = x^T Ax$  (with  $A = A^T \in \mathbf{R}^{n \times n}$ ) be a quadratic form.

- (a) Show that  $f$  is positive semidefinite (*i.e.*,  $A \geq 0$ ) if and only if it can be expressed as  $f(x) = \|Fx\|^2$  for some matrix  $F \in \mathbf{R}^{k \times n}$ . Explain how to find such an  $F$  (when  $A \geq 0$ ). What is the size of the smallest such  $F$  (*i.e.*, how small can  $k$  be)?
- (b) Show that  $f$  can be expressed as a difference of squared norms, in the form  $f(x) = \|Fx\|^2 - \|Gx\|^2$ , for some appropriate matrices  $F$  and  $G$ . How small can the sizes of  $F$  and  $G$  be?

5. *Congruences and quadratic forms.* Suppose  $A = A^T \in \mathbf{R}^{n \times n}$ .

- (a) Let  $Z \in \mathbf{R}^{n \times p}$  be any matrix. Show that  $Z^T AZ \geq 0$  if  $A \geq 0$ .
- (b) Suppose that  $T \in \mathbf{R}^{n \times n}$  is invertible. Show that  $T^T AT \geq 0$  if and only if  $A \geq 0$ . When  $T$  is invertible,  $TAT^T$  is called a *congruence* of  $A$  and  $TAT^T$  and  $A$  are said to be *congruent*. This problem shows that congruences preserve positive semidefiniteness.

6. *Positive semidefinite (PSD) matrices.*

- (a) Show that if  $A$  and  $B$  are PSD and  $\alpha \in \mathbf{R}$ ,  $\alpha \geq 0$ , then so are  $\alpha A$  and  $A + B$ .
- (b) Show that any (symmetric) submatrix of a PSD matrix is PSD. (To form a symmetric submatrix, choose any subset of  $\{1, \dots, n\}$  and then throw away all other columns and rows.)
- (c) Show that if  $A \geq 0$ ,  $A_{ii} \geq 0$ .
- (d) Show that if  $A \geq 0$ ,  $|A_{ij}| \leq \sqrt{A_{ii}A_{jj}}$ . In particular, if  $A_{ii} = 0$ , then the entire  $i$ th row and column of  $A$  are zero.

7. *Gram matrices.* Given functions  $f_i : [a, b] \rightarrow \mathbf{R}$ ,  $i = 1, \dots, n$ , the *Gram matrix*  $G \in \mathbf{R}^{n \times n}$  associated with them is defined by

$$G_{ij} = \int_a^b f_i(t)f_j(t) dt.$$

- (a) Show that  $G = G^T \geq 0$ .
- (b) Show that  $G$  is singular if and only if the functions  $f_1, \dots, f_n$  are linearly dependent.
8. Express  $\sum_{i=1}^{n-1} (x_{i+1} - x_i)^2$  in the form  $x^T P x$  with  $P = P^T$ . Is  $P \geq 0$ ?  $P > 0$ ?
9. Suppose  $A$  and  $B$  are symmetric matrices that yield the same quadratic form, *i.e.*,  $x^T A x = x^T B x$  for all  $x$ . Show that  $A = B$ .

*Hint:* first try  $x = e_i$  (the  $i$ th unit vector) to conclude that the entries of  $A$  and  $B$  on the diagonal are the same; then try  $x = e_i + e_j$ .

10. *A power method for computing  $\|A\|$ .* The following method can be used to compute the largest singular value ( $\sigma_1$ ), and also the corresponding left and right singular vectors ( $u_1$  and  $v_1$ ) of  $A \in \mathbf{R}^{m \times n}$ . You can assume (to simplify) that the largest singular value of  $A$  is isolated, *i.e.*,  $\sigma_1 > \sigma_2$ . Let  $z(0) = a \in \mathbf{R}^n$  be nonzero, and then repeat the iteration

$$w(t) = Az(t); \quad z(t+1) = A^T w(t);$$

for  $t = 1, 2, \dots$ . For large  $t$ ,  $w(t)/\|w(t)\| \approx u_1$  and  $z(t)/\|z(t)\| \approx v_1$ .

Analyze this algorithm. Show that it ‘usually’ works. Be very explicit about when it fails. (In practice it always works.)

11. *Optimal time compression equalizer.* We are given the (finite) impulse response of a communications channel, *i.e.*, the real numbers

$$c_1, c_2, \dots, c_n.$$

Our goal is to design the (finite) impulse response of an equalizer, *i.e.*, the real numbers

$$w_1, w_2, \dots, w_n.$$

(To make things simple, the equalizer has the same length as the channel.)

The equalized channel response  $h$  is given by the convolution of  $w$  and  $c$ , *i.e.*,

$$h_i = \sum_{j=1}^{i-1} w_j c_{i-j}, \quad i = 2, \dots, 2n.$$

This is shown below.



The goal is to choose  $w$  so that most of the energy of the equalized impulse response  $h$  is *concentrated* within  $k$  samples of  $t = n + 1$ , where  $k < n - 1$  is given. To define this formally, we first define the total energy of the equalized response as

$$E_{\text{tot}} = \sum_{i=2}^{2n} h_i^2,$$

and the energy in the desired time interval as

$$E_{\text{des}} = \sum_{i=n+1-k}^{n+1+k} h_i^2.$$

For any  $w$  for which  $E_{\text{tot}} > 0$ , we define the *desired to total energy ratio*, or DTE, as  $\text{DTE} = E_{\text{des}}/E_{\text{tot}}$ . This number is clearly between 0 and 1; it tells us what fraction of the energy in  $h$  is contained in the time interval  $t = n + 1 - k, \dots, t = n + 1 + k$ . You can assume that  $h$  is such that for any  $w \neq 0$ , we have  $E_{\text{tot}} > 0$ .

- (a) How do you find a  $w \neq 0$  that maximizes DTE? You must give a very clear description of your method, and explain why it works. Your description and justification must be *very clear*. You can appeal to any concepts used in the class, *e.g.*, least-squares, least-norm, eigenvalues and eigenvectors, singular values and singular vectors, matrix exponential, and so on.
- (b) Carry out your method for time compression length  $k = 1$  on the data found in `time_comp_data.m`. Plot your solution  $w$ , the equalized response  $h$ , and give the DTE for your  $w$ .

**Please note:** You do not need to know anything about equalizers, communications channels, or even convolution; everything you need to solve this problem is clearly defined in the problem statement.