

-
-
-

Packet, Frames, ...

Headers and trailers (soh, eoh, ...)

Error Control: Parity bits, checksums, ...

ISO OSI Stack

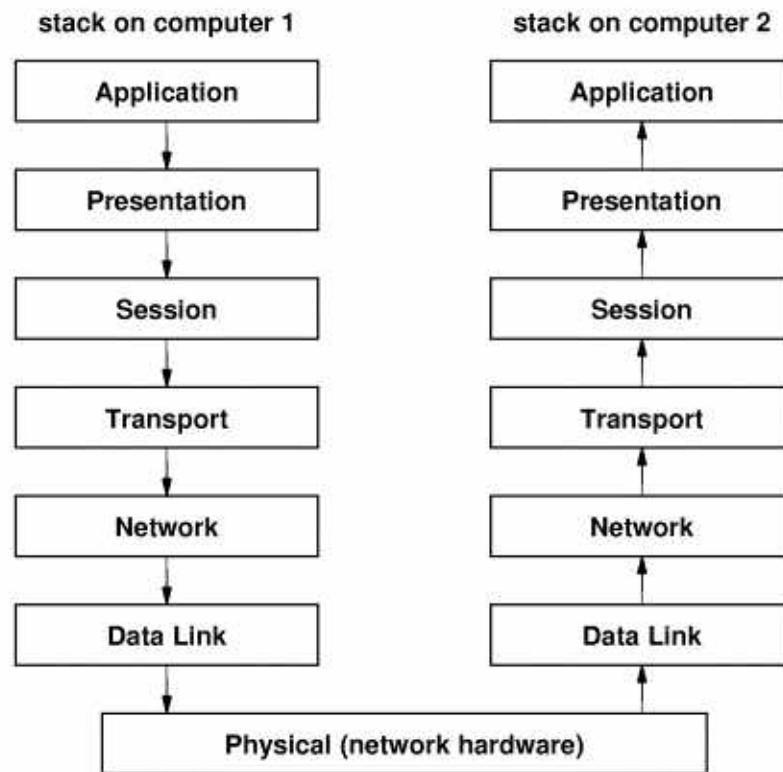

-
-
-

Data and Network Layers

<u>Layer</u>	<u>Data Unit</u>	<u>Connection Device</u>
Application		
Presentation		
Session		
Transport	Message	
Network	Packet	Router
Data Link	Frame	Bridge
Physical	Symbol (bit)	Modem/ Repeater

LAN Hardware

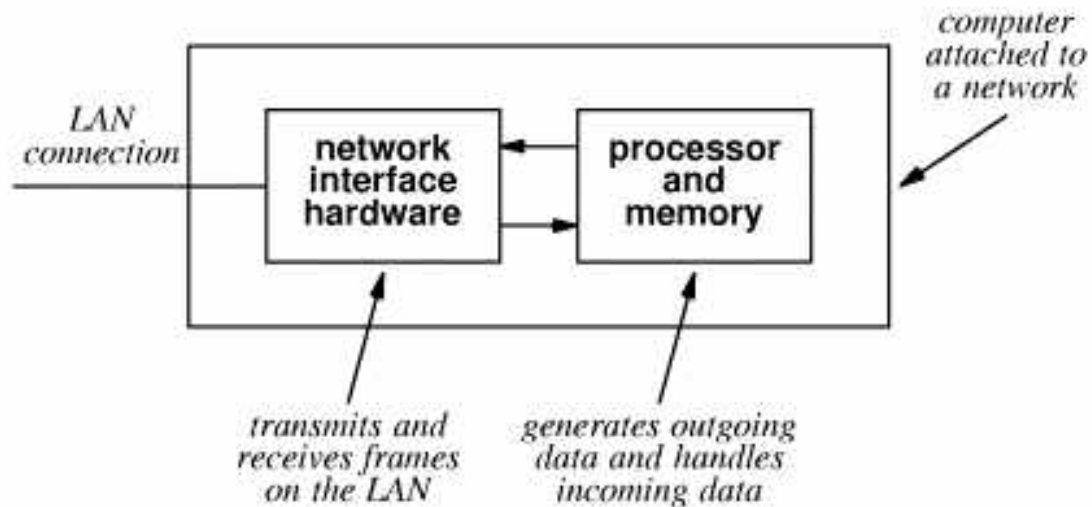

-
-
-

Addressing

Frames contain physical address of intended recipient (128.114.13.50)

Static

Configurable

Dynamic

-
-
-

Addressing

Broadcasting

Multicasting

Application (user) chooses
to accept multicasts

Choose among multicasts

Bridging LANs

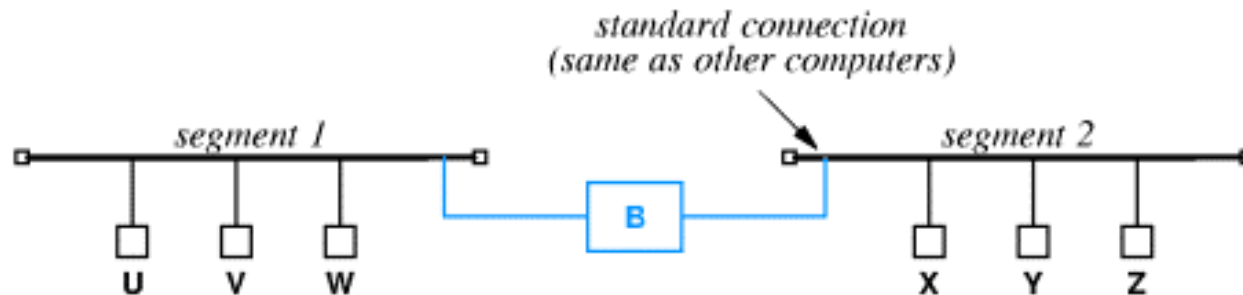

Forward frames *if necessary*
learns locations by listening
(promiscuous mode)
Adaptive Bridge

-
-
-

Bridged Network

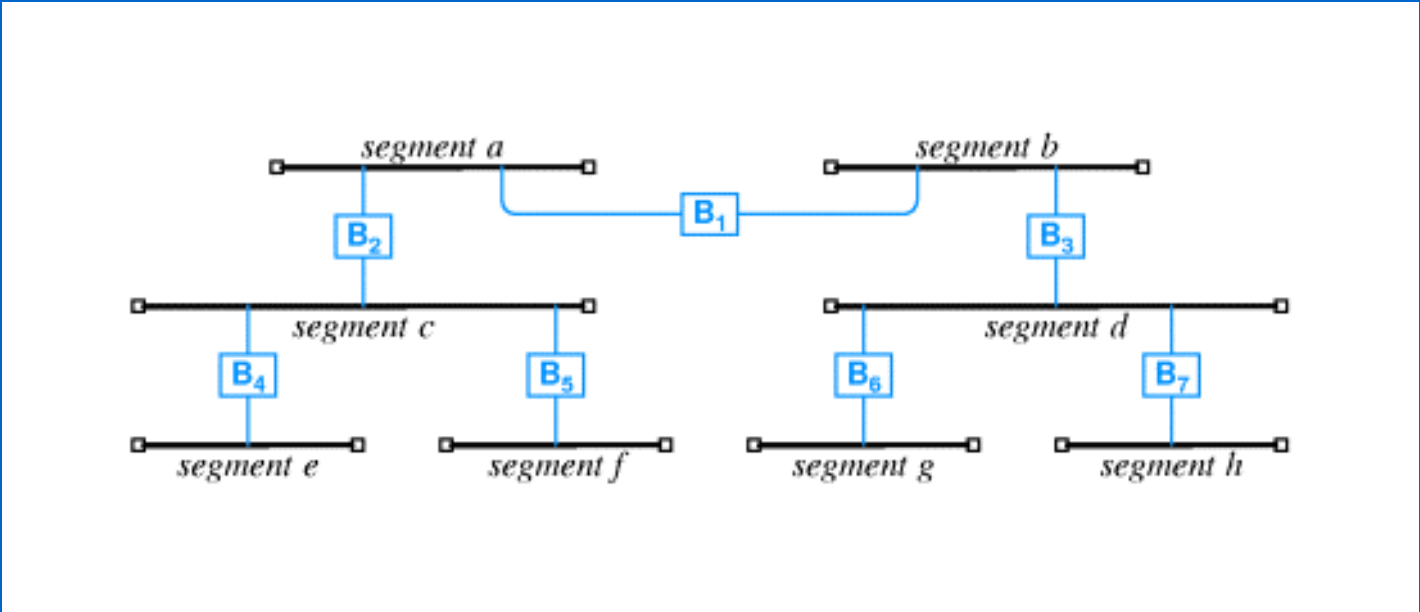

-
-
-

Switched LANs

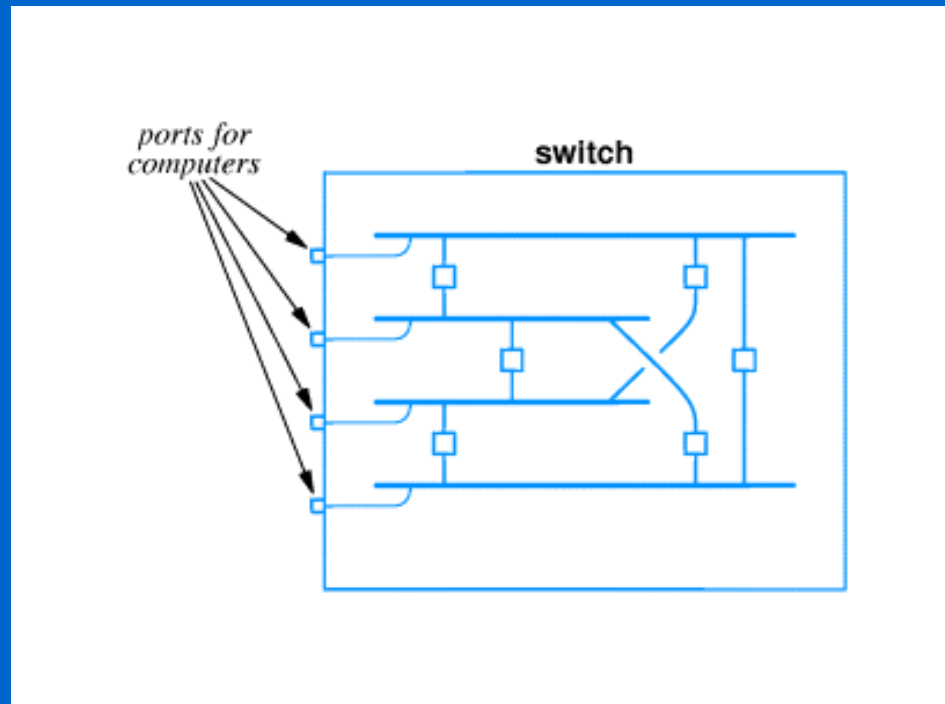

Each computer has (simulated) LAN of its own

-
-
-

Bridges vs. Switches

Switches give greater bandwidth utilization

Switches cost more

Combination of Hubs and Switches

hubs connect to switch ports
computers connect to hubs

Connecting via Teleco Circuits

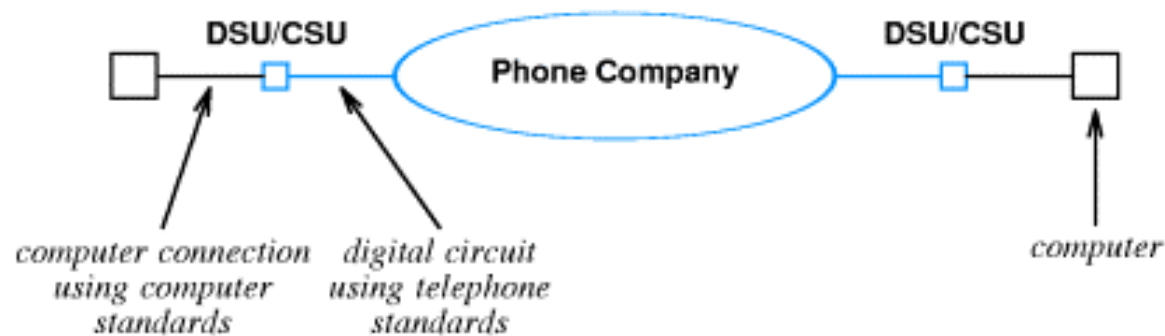

DSU/CSU: Data Service Unit / Channel Service Unit

ISO OSI Stack

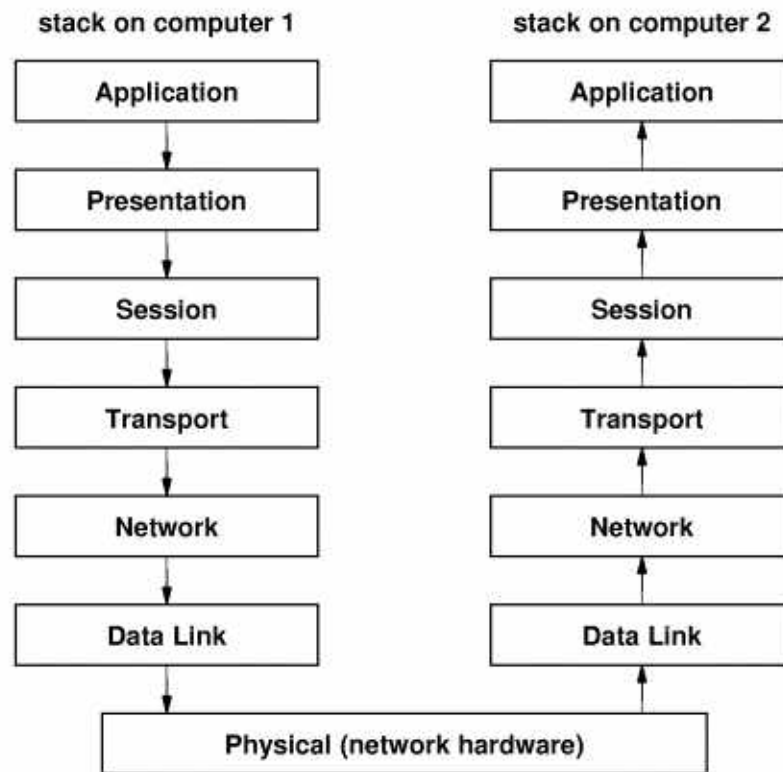

-
-
-

TCP/IP Protocol

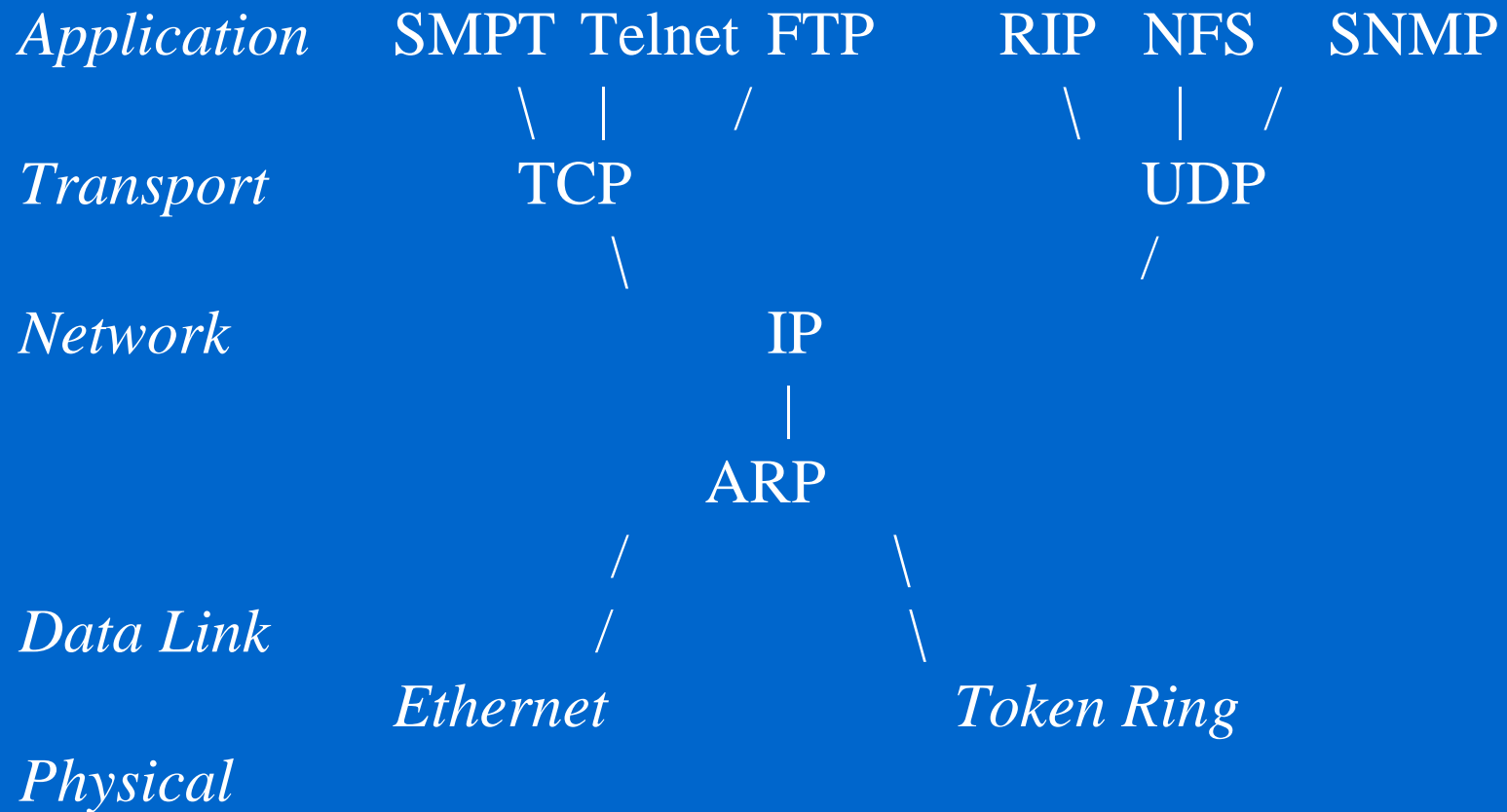

-
-
-

TCP/ IP Protocol

SMTP	Simple Mail Transfer Protocol
Telnet	Network Teletype (remote virtual terminal)
FTP	File Transfer Protocol
RIP	Routing Information Protocol
NFS	Network File System
SNMP	Simple Network Management Protocol
TCP	Transmission Control Protocol
UDP	User Datagram Protocol
IP	Internet Protocol
ARP	Address Resolution Protocol